

EXPLODED VIEW & PARTS LISTING

Air Operated Double Diaphragm Pump

Model: NDP-5FVT

Model # 852064



To Purchase:

☎ 800-990-7867

✉ sales@yamadapump.com

📍 [Find My Rep](#)

More Information:

▶ YouTube: [@yamadapump](#)

🌐 yamadapump.com

[Data Sheets](#) | [CAD Drawings](#) | [Manuals](#)
[Literature](#) | [BOM](#) | [Performance Curves](#)

Trial Program

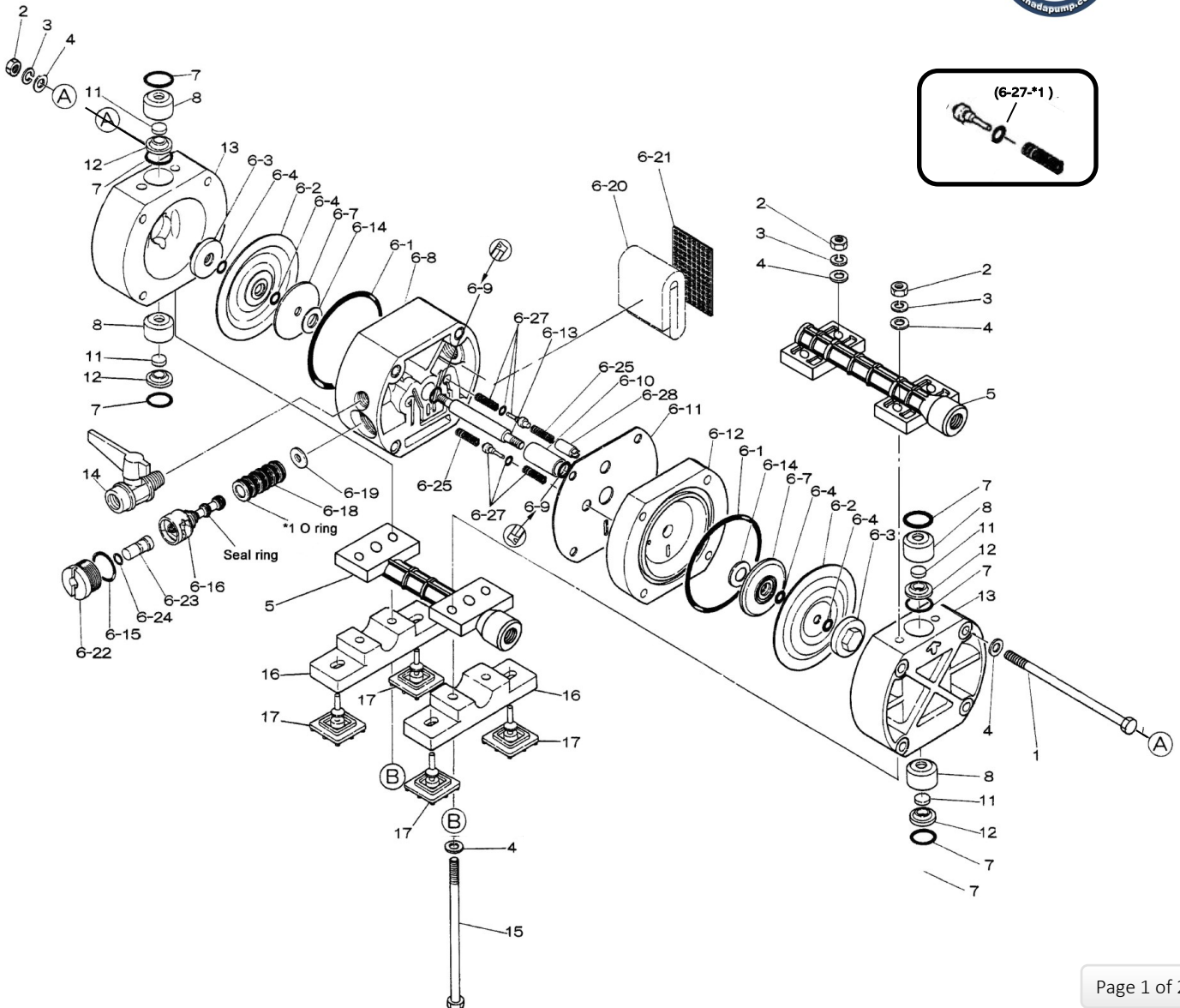

Air Operated Double Diaphragm Pump

[CLICK HERE FOR TORQUE](#)

REF. No.	PART No.	DESCRIPTION	QTY.
1	682748	BOLT	4
2	687228	NUT	8
3	681855	SPRING LOCK WASHER	8
4	631328	PLAIN WASHER	16
5	780053	MANIFOLD	2
6	BODY ASSY.		
6-1	640139	O-RING	2
6-2	771093	DIAPHRAGM	2
6-3	771579	CENTER DISK (OUTER)	2
6-4	643003	O-RING	4
6-7	709317	CENTER DISK (INNER)	2
6-8	780006	BODY A	1
6-9	685752	PACKING	2
6-10	771088	BUSHING	1
6-11	771980	GASKET	1
6-12	780001	BODY B	1
6-13	709316	CENTER ROD	1
6-14	771239	CUSHION	2
6-15	640017	O-RING	1
6-16	802386	C-SPOOL VALVE ASSY.	1
6-16 seal	771098	SEAL RING	5
6-18	802049	SLEEVE ASSY.	1
6-18-*1	771097	O-RING (SLEEVE O.D.)	6
6-19	771096	CUSHION	1
6-20	771465	SILENCER	1
6-21	771589	MESH	1
6-22	771100	CAP	1
6-23	771099	RESET BUTTON	1
6-24	640002	O-RING	1
6-25	709319	SPRING	2
6-27	803510	PILOT VALVE ASSY.	2
6-27-*1	640000	O-RING (PILOT VALVE ASSY.)	2
6-28	771095	STOPPER	1
7	643015	O-RING	6
8	771581	VALVE STOPPER	4
11	771094	FLAT VALVE	4
12	772735	VALVE SEAT	4
13	780232	OUT CHAMBER	2
14	686826	BALL VALVE	1
15	682747	BOLT	4
16	771648	BASE	2
17	771102	CUSHION	4
KIT	K5-VT-2	LIQUID SIDE KIT	
KIT	K5-AM	AIR MOTOR KIT	

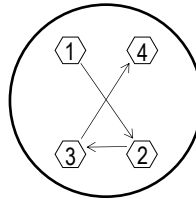

General Tools:

- Socket wrench - 10mm
- Open-end wrenches - 10mm
- Plyer

Special Tools (sold separately):

- Cap and disk remover (771132)
- Sleeve remover (713148)

Miscellaneous:

- Nuts - M6 x 1
- Urea grease grade (NLGI) No. 2 for Center Rod (Ref# 6-13)

[CLICK HERE FOR MAINTENANCE MANUAL](#)

Customer Notes

Model #: _____
 Description: _____
 Serial #: _____
 Date Installed: _____
 Department Location: _____
 Tag/Project: _____