

Pulsation Dampener



To Purchase:

- ☎ [800-990-7867](tel:800-990-7867)
- ✉ sales@yamadapump.com
- 📍 [Find My Rep](#)

More Information:

- ▶ YouTube: [@yamadapump](#)
- 🌐 yamadapump.com
- [Data Sheets](#) | [CAD Drawings](#) | [Manuals](#)
[Literature](#) | [BOM](#) | [Performance Curves](#)

Trial Program

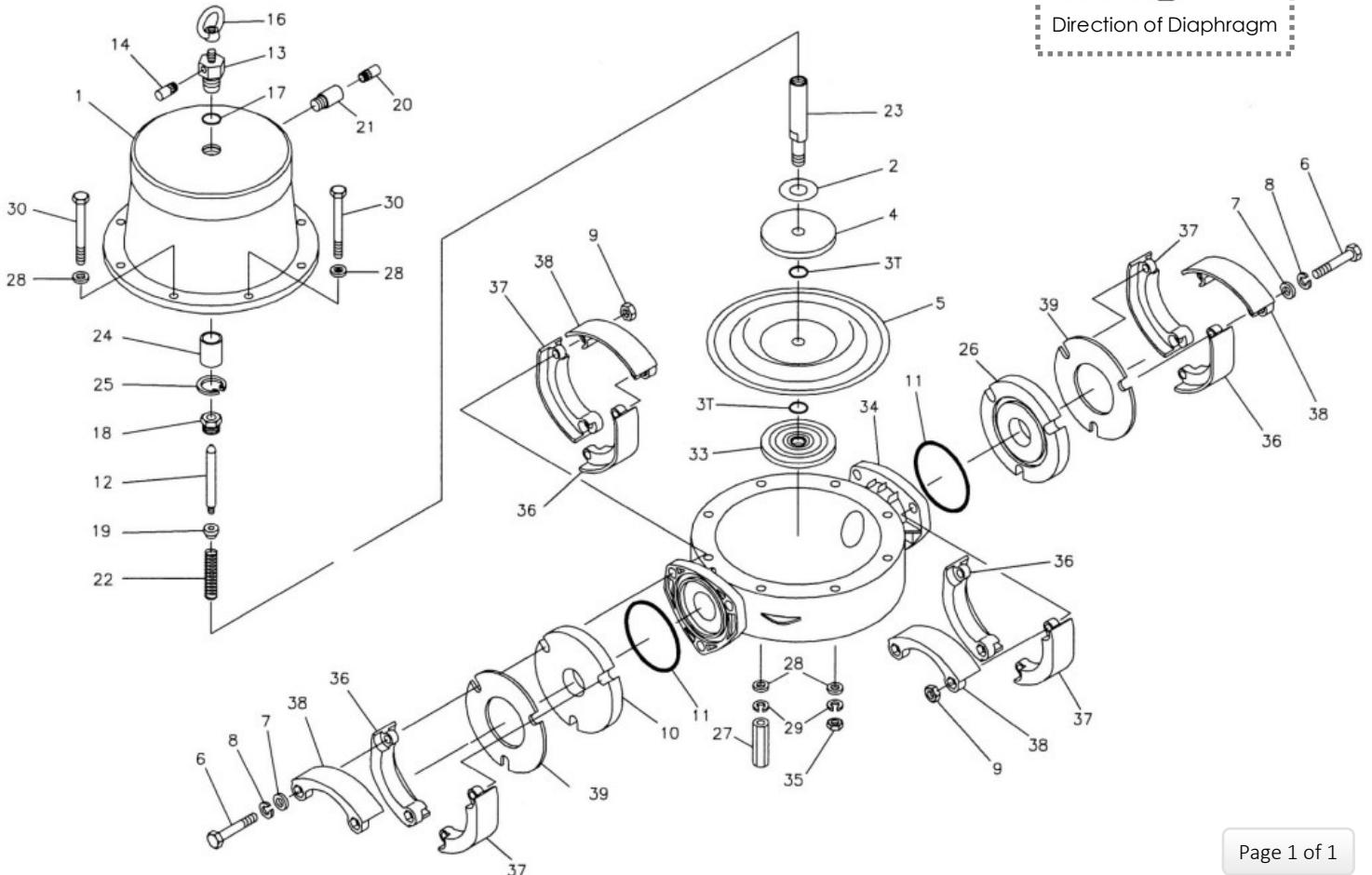
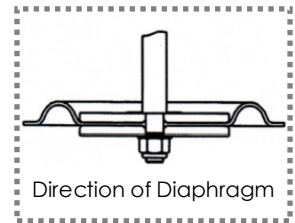

Pulsation Dampener

Ref No.	Item Code	Description	Qty.
1	713310	AIR CHAMBER	1
2	771316	CUSHION	1
3T	643015	O RING	2
4	707822	CENTER DISK	1
5	770815	DIAPHRAGM	1
6	621213	BOLT	6
7	631331	PLAIN WASHER	6
8	680607	SPRING LOCK WASHER	6
9	687296	NUT	6
10	772223	FLANGE OUT	1
11	772063	O RING	2
12	795081	VALVE	1
13	716408	VALVE SEAT	1
14	802569	SILENCER ASSEMBLY	1
16	630241	EYE NUT	1
17	640017	O RING	1
18	710717	NUT	1
19	710719	NUT	1
20	681170	SILENCER	1
21	714085	UNION	1
22	710762	SPRING	1
23T	713242	CENTER ROD	1
24	773092	THROAT BEARING	1
25	630807	RETAINING RING R TYPE	1
26	772222	FLANGE IN	1
27	713243	STUD	4
28	631330	PLAIN WASHER	16
29	680257	SPRING LOCK WASHER	8
30	683542	BOLT	8
33T	780116	CENTER DISK	1
34	780153	OUT CHAMBER	1
35	687295	NUT	4
36	771786	PROTECTOR A	4
37	771787	PROTECTOR B	4
38	771788	PROTECTOR C	4
39	714104	REINFORCEMENT PLATE	2

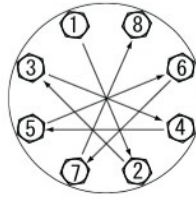

[CLICK HERE FOR TORQUE](#)



General Tools:

- Socket wrench - 17mm, 19mm, 24mm
- Box Wrench - 17mm, 19mm
- Snap Plyer
- Adjustable Angle Wrenches
- Flat-Blade Screw Driver

Miscellaneous:

- Thread Locking Agent—Equivalent to LOCTITE® 222
- Urea grease grade (NLGI) No. 2 for Center Rod (Ref# 22)

[MAINTENANCE MANUAL](#)

Customer Notes

Model #: _____

Description: _____

Serial #: _____

Date Installed: _____

Department Location: _____

Tag/Project: _____